

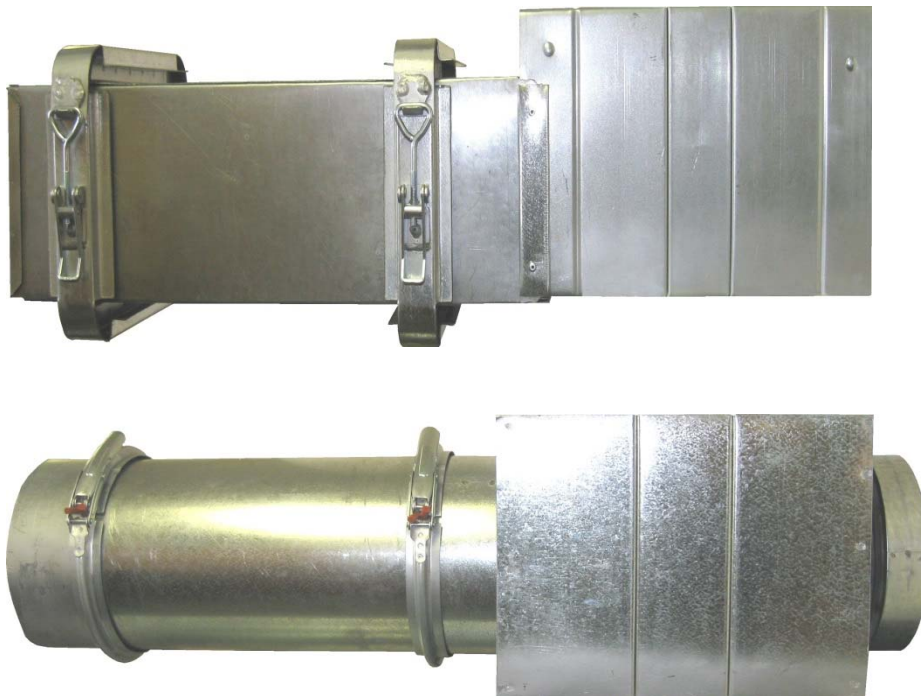

Sure-Clamp™ Access



9865 WAYNE AVENUE CINCINNATI, OHIO 45215
PHONE (513) 733-5955 FAX (513) 733-8050

<http://www.langdonsheetmetal.com>

Sure-Clamp™ Access

Rectangular or Round
(patent-pending)

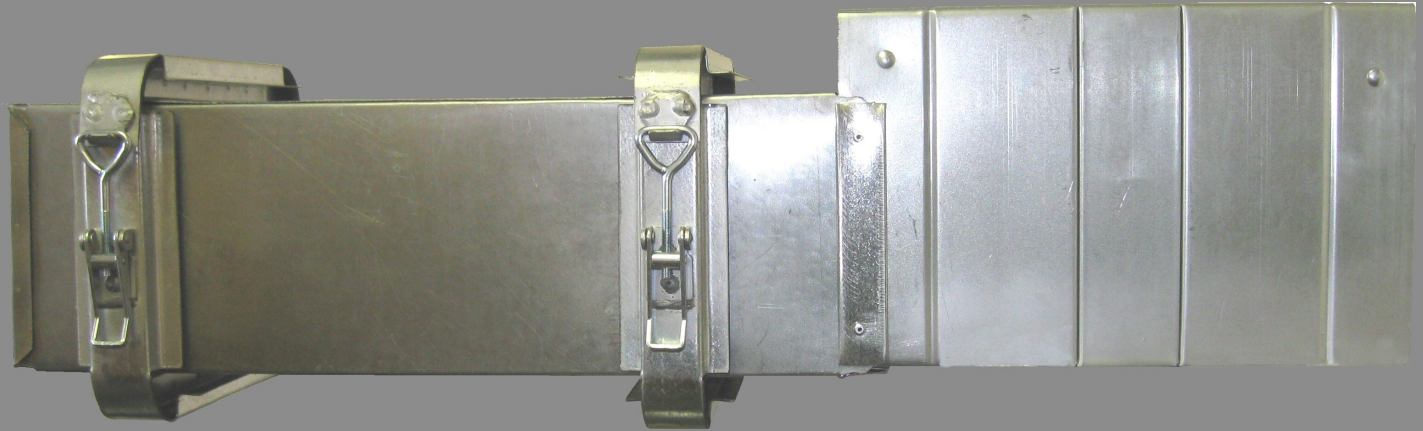

Rectangular
Access Section

Fire Damper

Sure-Clamp™ Access Allows For :

- **CODE COMPLIANCE**

Fire dampers must be maintained according to NFPA 80 and smoke dampers must be maintained to NFPA 105

- **INSPECTION INTERVALS**

Dampers must be inspected and tested one year after installation and every four years after that (six years for hospitals)

- **INSPECTION REQUIREMENTS**

The damper shall fully close from the open position and all exposed moving parts of the damper shall be dry lubricated as required by the manufacturer.

- **PROPER SERVICE ACCESS**

A Sure-Clamp™ Access will provide a technician with 18" of access to properly service the dampers in a very short period of time.

IMPROVE THE QUALITY AND REDUCE THE COST OF YOUR COMPLIANCE

As a building owner, the new fire and smoke damper inspection requirements create further challenges for existing duct construction methods. More specifically proper access to these dampers. It is next to impossible to properly maintain your fire and smoke dampers unless you have adequate access to them. **NFPA 80(2013) 19.2.3 Access** states Dampers equipped with fusible links, internal operators, or both shall be provided with an access door that is not less than 12 in. (305mm) square or provided with a removable duct section. Working through an access door causes poor quality inspections that increase your exposure to lawsuits. By installing a Sure-Clamp™ Access, a technician is able to properly inspect your dampers for mandatory requirements while taking less time to make these inspections. This removable duct section allows the technician to comply with the maintenance requirements of Section **19.5 of NFPA 80(2013)**. Reduce your costs and maintain your compliance by demanding Sure-Clamp™ Access be installed in your HVAC system.

Sure-Clamp™ Access

Rectangular or Round
(patent-pending)

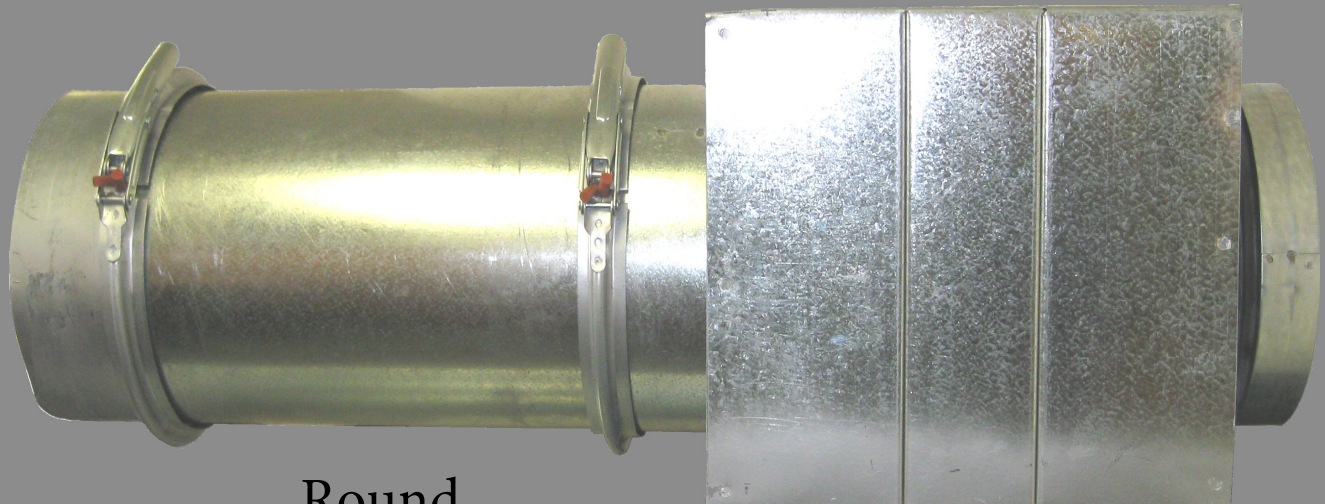

Round
Access Section

Fire Damper

Sure-Clamp™ Access Allows For :

- **CODE COMPLIANCE**

Fire dampers must be maintained according to NFPA 80 and smoke dampers must be maintained to NFPA 105

- **INSPECTION INTERVALS**

Dampers must be inspected and tested one year after installation and every four years after that (six years for hospitals)

- **INSPECTION REQUIREMENTS**

The damper shall fully close from the open position and all exposed moving parts of the damper shall be dry lubricated as required by the manufacturer.

- **PROPER SERVICE ACCESS**

A Sure-Clamp™ Access will provide a technician with 18" of access to properly service the dampers in a very short period of time.

IMPROVE THE QUALITY AND REDUCE THE COST OF YOUR COMPLIANCE

As a building owner, the new fire and smoke damper inspection requirements create further challenges for existing duct construction methods. More specifically proper access to these dampers. It is next to impossible to properly maintain your fire and smoke dampers unless you have adequate access to them. **NFPA 80(2013) 19.2.3 Access** states Dampers equipped with fusible links, internal operators, or both shall be provided with an access door that is not less than 12 in. (305mm) square or provided with a removable duct section. Working through an access door causes poor quality inspections that increase your exposure to lawsuits. By installing a Sure-Clamp™ Access, a technician is able to properly inspect your dampers for mandatory requirements while taking less time to make these inspections. This removable duct section allows the technician to comply with the maintenance requirements of Section **19.5 of NFPA 80(2013)**. Reduce your costs and maintain your compliance by demanding Sure-Clamp™ Access be installed in your HVAC system.

NFPA ® 80 - 2013 Edition

19.2.3 Access. Dampers equipped with fusible links, internal operators, or both shall be provided with an access door that is not less than 12 in. (305 mm) square or provided with a removable duct section.

19.4* Periodic Inspection and Testing.

19.4.1 Each damper shall be tested and inspected 1 year after installation.

19.4.1.1 The test and inspection frequency shall then be every 4 years, except in hospitals, where the frequency shall be every 6 years.

19.4.2 All tests shall be completed in a safe manner by personnel wearing personal protective equipment.

19.4.3 Full unobstructed access to the fire or combination fire/smoke damper shall be verified and corrected as required.

19.4.4 If the damper is equipped with a fusible link, the link shall be removed for testing to ensure full closure and lock-in place if so equipped.

19.4.5 The operational test of the damper shall verify that there is no damper interference due to rusted, bent, misaligned, or damaged frame or blades, or defective hinges or other moving parts.

19.4.6 The damper frame shall not be penetrated by any foreign objects that would affect fire damper operations.

19.4.7 The damper shall not be blocked from closure in any way.

19.4.8 The fusible link shall be reinstalled after testing is complete.

19.4.8.1 If the link is damaged or painted, it shall be replaced with a link of the same size, temperature, and load rating.

NFPA ® 80 - 2013 Edition

19.4.9 All inspections and testing shall be documented, indicating the location of the ceiling radiation damper, fire damper, or combination fire/smoke damper, date of inspection, name of inspector, and deficiencies discovered.

19.4.9.1 The documentation shall have a space to indicate when and how the deficiencies were corrected.

19.4.10 All documentation shall be maintained and made available for review by the AHJ.

19.4.11 Periodic inspections and testing of a combination fire/smoke damper shall also meet the inspection and testing requirements contained in Chapter 6 of NFPA 105, Standard for Smoke Door Assemblies and Other Opening Protectives.

19.5 Maintenance.

19.5.1 Reports of changes in airflow or noise from the duct system shall be investigated to verify that they are not related to damper operation.

19.5.2* All exposed moving parts of the damper shall be dry lubricated as required by the manufacturer.

19.5.3 If the damper is not operable, repairs shall begin without delay.

19.5.4 Following any repairs, the damper shall be tested for operation in accordance with Section 19.4.

19.5.5 All maintenance shall be documented in accordance with 19.4.9 and 19.4.10.

19.5.6 Maintenance of a combination fire/smoke damper shall also meet the maintenance requirements contained in Chapter 6 of NFPA 105, Standard for Smoke Door Assemblies and Other Opening Protectives.

FIRE/SMOKE DAMPER MAINTENANCE RECORD

Date: _____

Inspector: _____

Location: _____

This is to certify that the following testing and maintenance was performed on the dampers listed. Any modifications or repairs made are described below.

Y = Satisfactory

N = Unsatisfactory

N/A = Not applicable

Damper number or location	Damper Type	Tested	Fully Closed	Latch Checked	Fusible Link Removed	Moving Parts Lubricated

COMMENTS: _____

Sure - Clamp Access Specifications

- A. General : **Fabricate rectangular access section** suitable for duct pressure class. Clamping type, removable ductwork section with draw latch.
- B. Provide : Sure Clamp access size as indicated on drawings.
- C. Size : 18" X 18" maximum ductwork size
- D. Material : Galvanized ASTM A527
- E. Flange Connection : 18 GA galvanized sheet metal construction.
- F. Seams : Pittsburgh Lock
- G. Access Section : Minimum 26 gauge galvanized sheet metal construction
- H. Clamps : 20 gauge galvanized with zinc coated draw latch and self centering flange guides. Gasket profile forms to the inside of clamp, sealing the outer edges of the ductwork flange.
- I. Gasket : Neoprene gasket 3/16 thick
- J. Seal seams in accordance with SMACNA HVAC Duct Construction Standard - Metal and Flexible.
- K. Manufacturer :

Langdon Inc.
9865 Wayne Ave Cincinnati, Ohio 45215
Phone (513)733-5955 ext.238 Fax (513)733-8050
www.langdonsheetmetal.com
Attn. : Joe Sandman. Mobile # 513-678-6825

Sure-Clamp Access

SURE • CLAMP™ ACCESS

(PATENT PENDING)

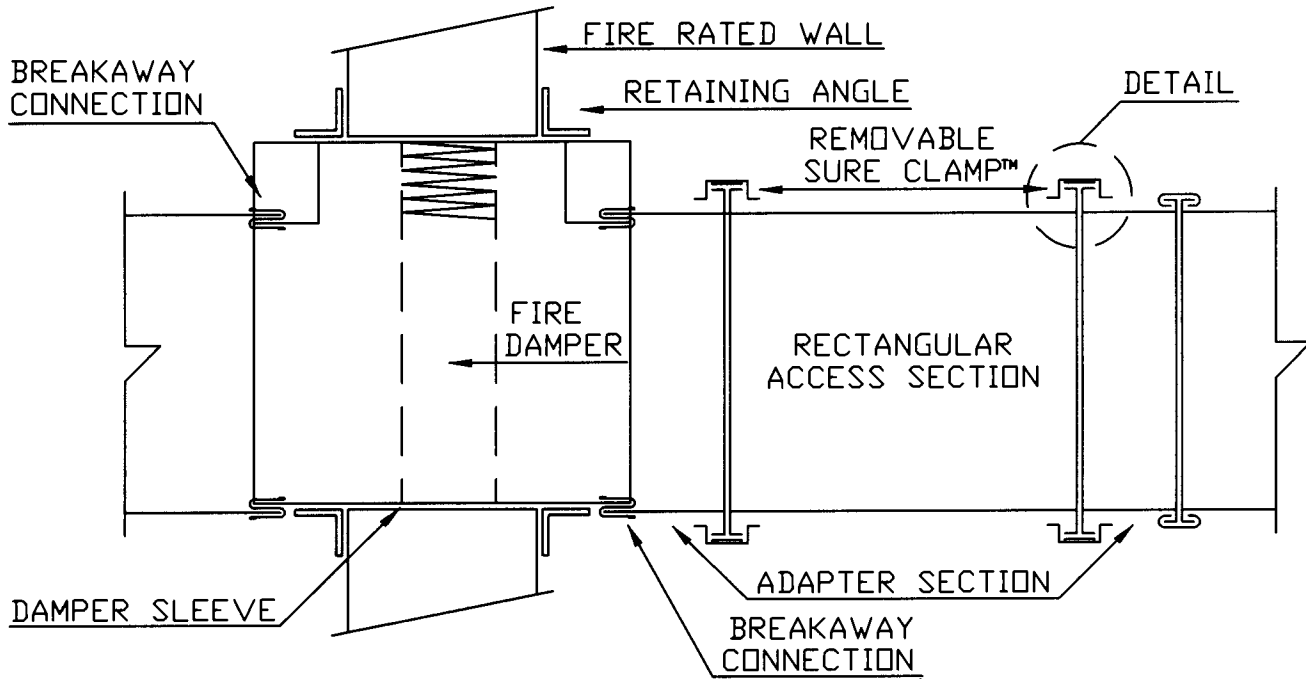

SURE CLAMP™ UNLINED DETAIL

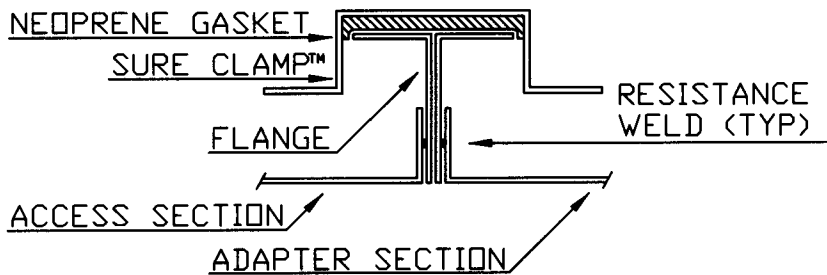

SURE CLAMP™ ADJUSTABLE DRAW LATCH DETAIL

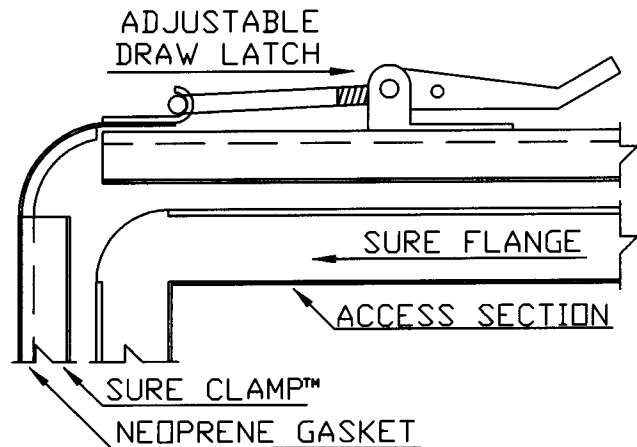

www.langdonsheetmetal.com

Langdon, Inc. 9865 Wayne Avenue, Cincinnati, Ohio, 45215 Ph. 513-733-5955 Fax. 513-733-8050
The above mentioned product, is protected by pending patents and trade marks
All Rights Reserved updated 3/13/13

Sure - Clamp Access Specifications

- A. General : **Fabricate rectangular access section with liner** suitable for duct pressure class. Clamping type, removable ductwork section with draw latch.
- B. Provide : Sure Clamp access size as indicated on drawings.
- C. Size : 18" X 18" maximum ductwork size
- D. Material : Galvanized ASTM A527
- E. Flange Connection : 18 GA galvanized sheet metal construction.
- F. Seams : Pittsburgh Lock
- G. Access Section : Minimum 26 gauge galvanized sheet metal construction
- H. Insulation : 1/2" Armaflex internally lined. Top surface even and on the same plane with adjoining ductwork.
- I. Clamps : 20 gauge galvanized with zinc coated draw latch and self centering flange guides. Gasket profile forms to the inside of clamp, sealing the outer edges of the ductwork flange.
- J. Gasket : Neoprene gasket 3/16 thick
- K. Seal seams in accordance with SMACNA HVAC Duct Construction Standard - Metal and Flexible.
- L. Manufacturer :

Langdon Inc.
9865 Wayne Ave Cincinnati, Ohio 45215
Phone (513)733-5955 ext.238 Fax (513)733-8050
www.langdonsheetmetal.com
Attn. : Joe Sandman. Mobile # 513-678-6825

Sure-Clamp Access

SURE • CLAMP™ ACCESS

(PATENT PENDING)

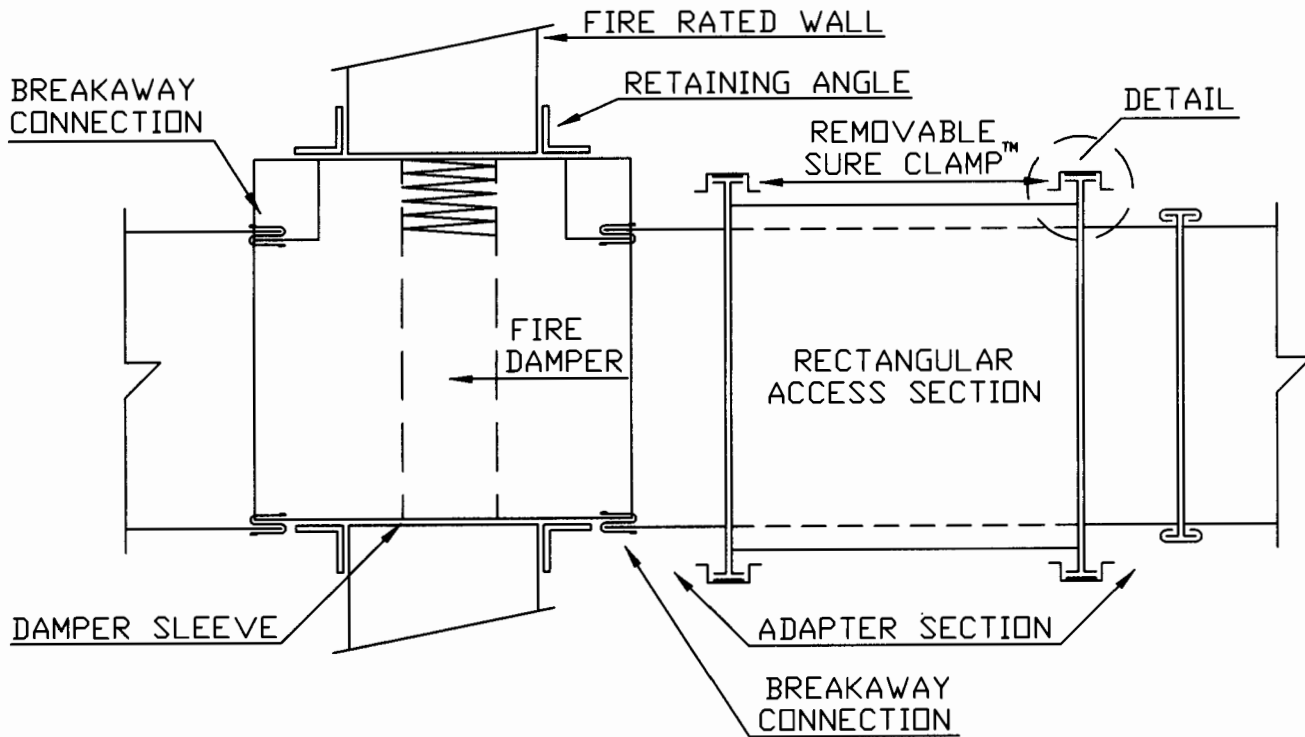

SURE CLAMP™ LINED DETAIL

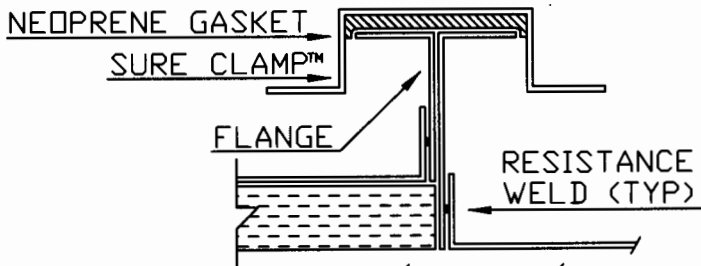

INTERNALLY LINED ACCESS SECTION

UNLINED ADAPTER SECTION

SURE CLAMP™ ADJUSTABLE DRAW LATCH DETAIL

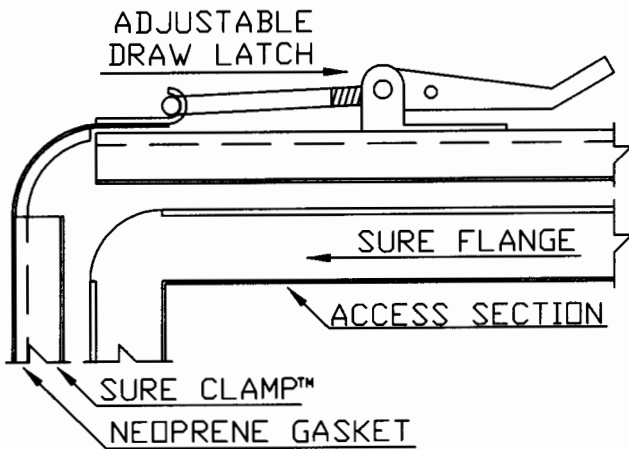

www.langdonsheetmetal.com

Langdon, Inc. 9865 Wayne Avenue, Cincinnati, Ohio. 45215 Ph. 513-733-5955 Fax. 513-733-8050
The above mentioned product, is protected by pending patents and trade marks
All Rights Reserved updated 3/13/13

Sure - Clamp Access Specifications

- A. General : **Fabricate round access section** suitable for duct pressure class. Clamping type, removable ductwork section with draw latch.
- B. Provide : Sure Clamp access size as indicated on drawings.
- C. Size : 22" maximum diameter
- D. Material : Galvanized ASTM A527
- E. Flange Connection : 90 degree continuous machine formed flange.
- F. Seams : (RL-3) Lap and spot weld on 2" interval
- G. Access Section : Galvanized sheet metal construction , 22 Gauge 4" to 12" diameter, 20 Gauge 13" to 22" diameter.
- H. Clamps : 20 gauge galvanized with zinc coated draw latch and self centering flange guides. Gasket profile forms to the inside of clamp, sealing the outer edges of the ductwork flange.
- I. Gasket : Red silicone sponge gasket. Temperature range - 40F to +400 F
- J. Seal seams in accordance with SMACNA HVAC Duct Construction Standard - Metal and Flexible.
- K. Manufacturer :

Langdon Inc.
9865 Wayne Ave Cincinnati, Ohio 45215
Phone (513)733-5955 ext.238 Fax (513)733-8050
www.langdonsheetmetal.com
Attn. : Joe Sandman. Mobile # 513-678-6825

Sure-Clamp Access

SURE • CLAMP™ ACCESS

(PATENT PENDING)

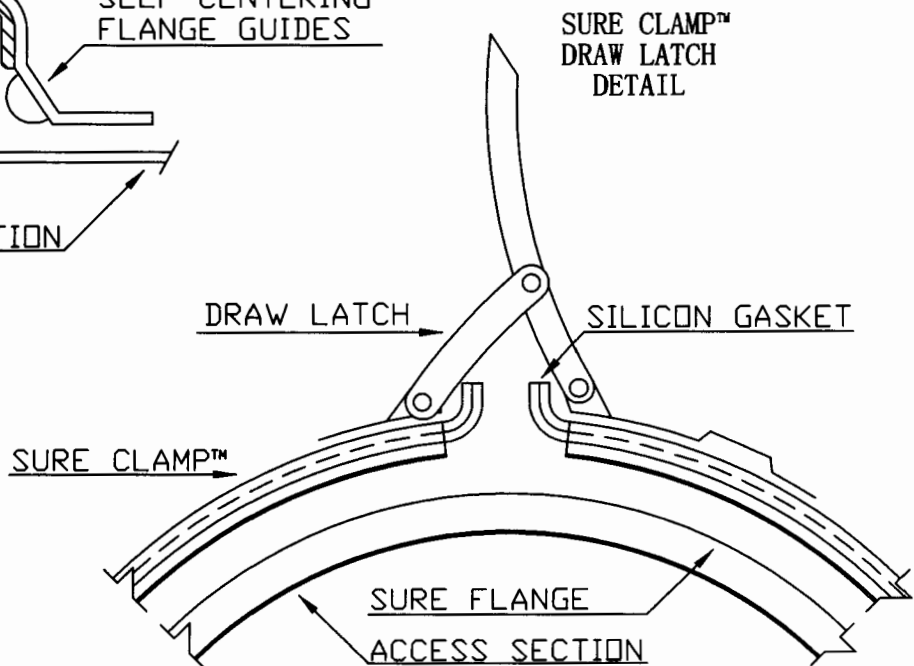
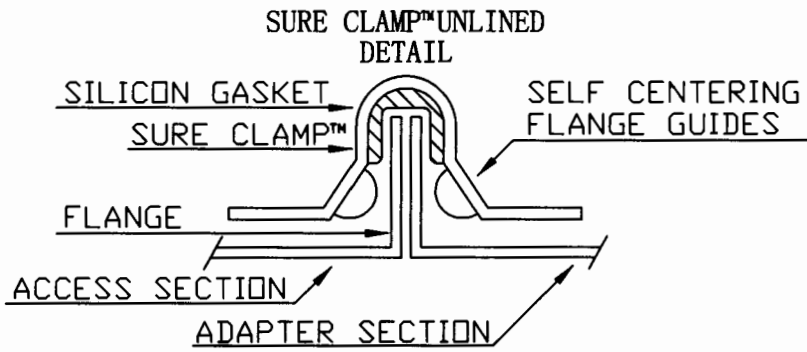
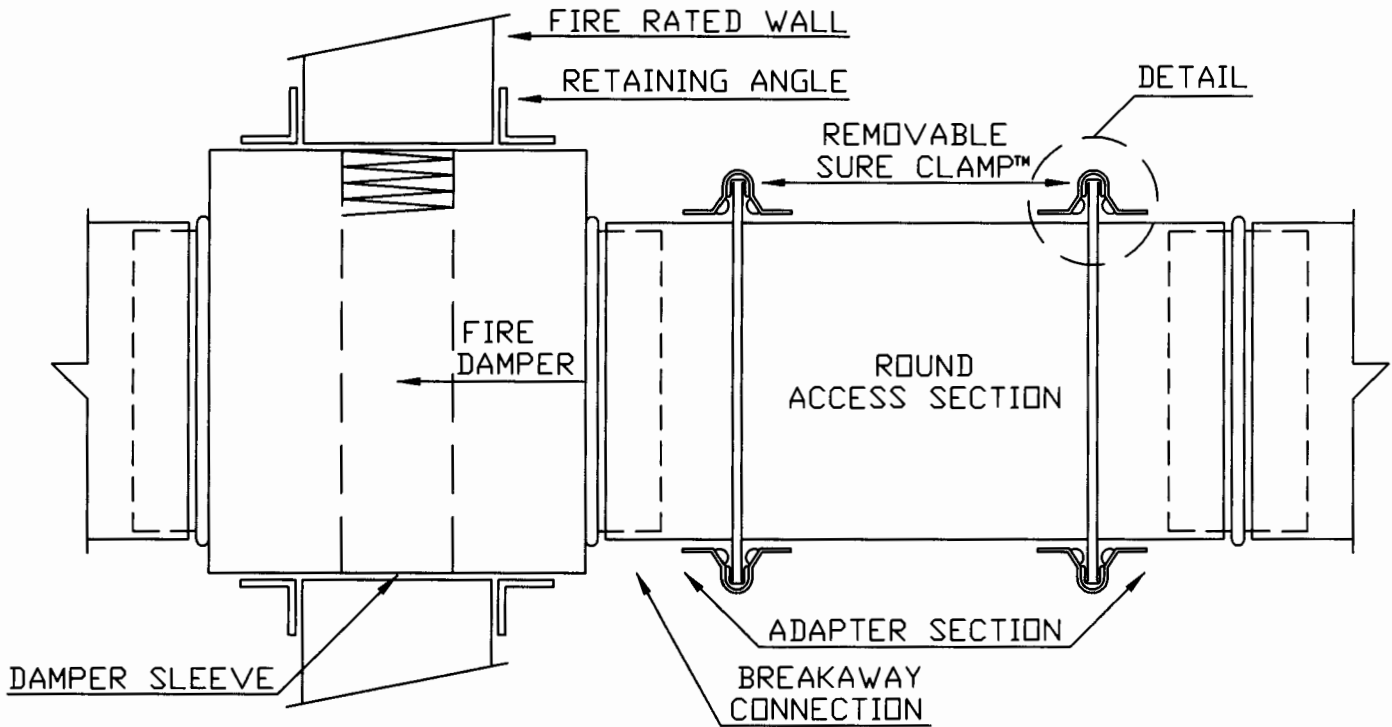

www.langdonsheetmetal.com

Cincinnati, Ohio. 45215
The above mentioned product, is protected by pending patents and trade marks
All Rights Reserved updated 3/14/13

Sure - Clamp Access Specifications

- A. General : **Fabricate round access section with liner** suitable for duct pressure class. Clamping type, removable ductwork section with draw latch.
- B. Provide : Sure Clamp access size as indicated on drawings.
- C. Size : 22" maximum diameter
- D. Material : Galvanized ASTM A527
- E. Flange Connection : 90 degree continuous machine formed flange.
- F. Seams : (RL-3) Lap and spot weld on 2" interval
- G. Access Section : Galvanized sheet metal construction , 22 Gauge 4" to 12" diameter, 20 Gauge 13" to 22" diameter.
- H. Insulation : 1/2" Armaflex internally lined. Top surface even and on the same plane with adjoining ductwork.
- I. Clamps : 20 gauge galvanized with zinc coated draw latch and self centering flange guides. Gasket profile forms to the inside of clamp, sealing the outer edges of the ductwork flange.
- J. Gasket : Red silicone sponge gasket. Temperature range - 40F to +400 F
- K. Seal seams in accordance with SMACNA HVAC Duct Construction Standard - Metal and Flexible.
- L. Manufacturer :

Langdon Inc.
9865 Wayne Ave Cincinnati, Ohio 45215
Phone (513)733-5955 ext.238 Fax (513)733-8050
www.langdonsheetmetal.com
Attn. : Joe Sandman. Mobile # 513-678-6825

Sure-Clamp Access

SURE • CLAMP™ ACCESS

(PATENT PENDING)

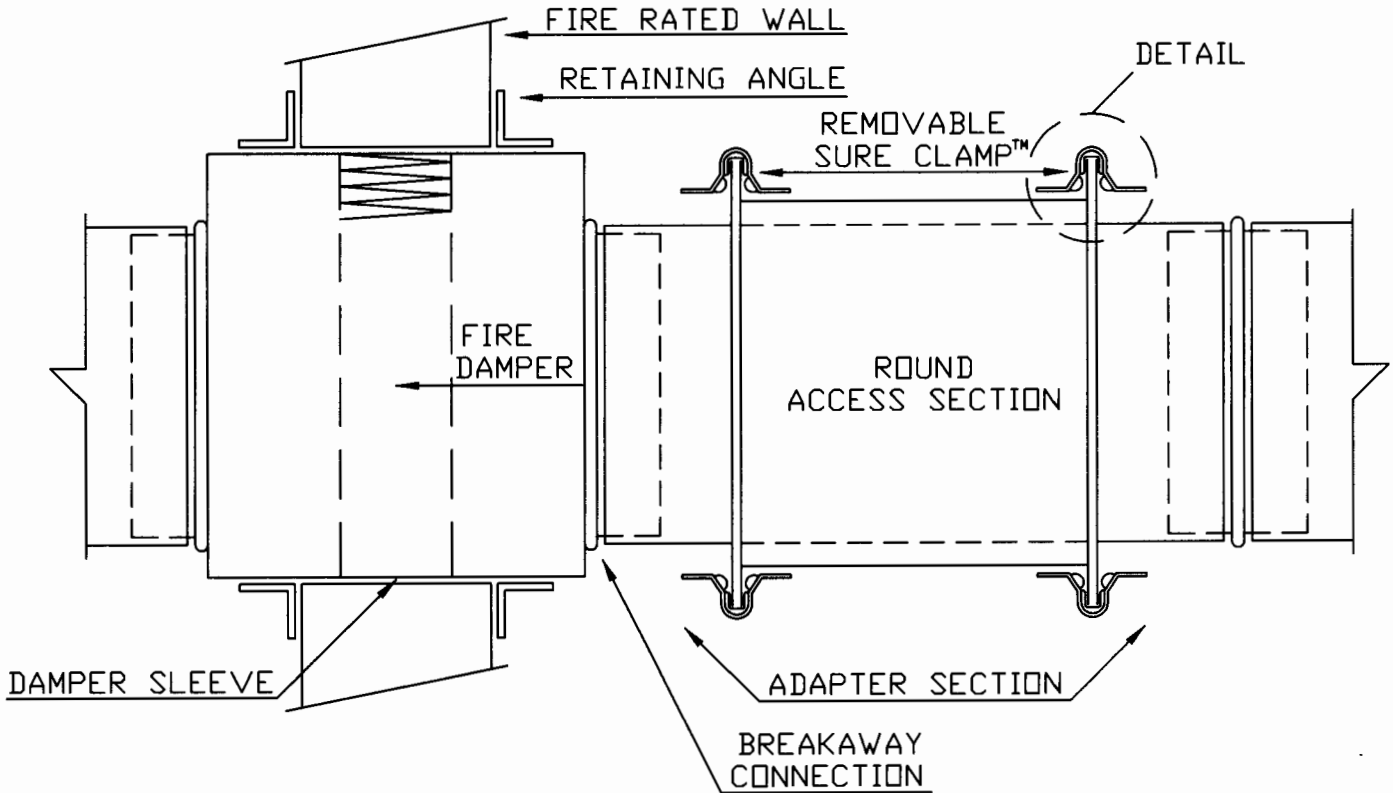

SURE CLAMP™ LINED DETAIL

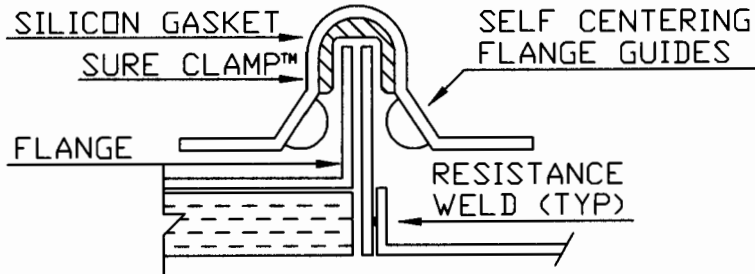

SURE CLAMP™ DRAW LATCH DETAIL

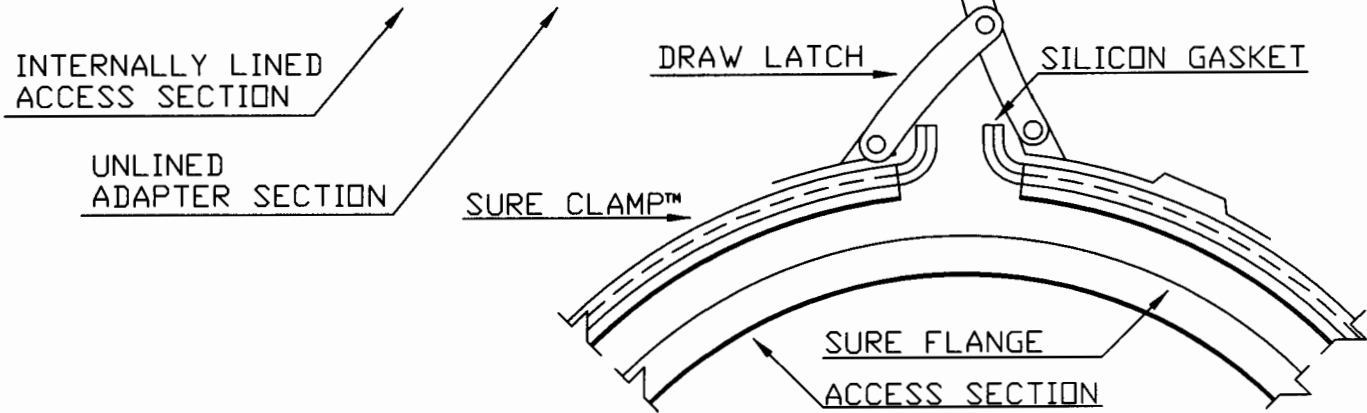

www.langdonsheetmetal.com

Cincinnati, Ohio. 45215

The above mentioned product, is protected by pending patents and trade marks
All Rights Reserved updated 3/14/13

ORDER FORM

SURE • CLAMP™ ACCESS

(PATENT PENDING)

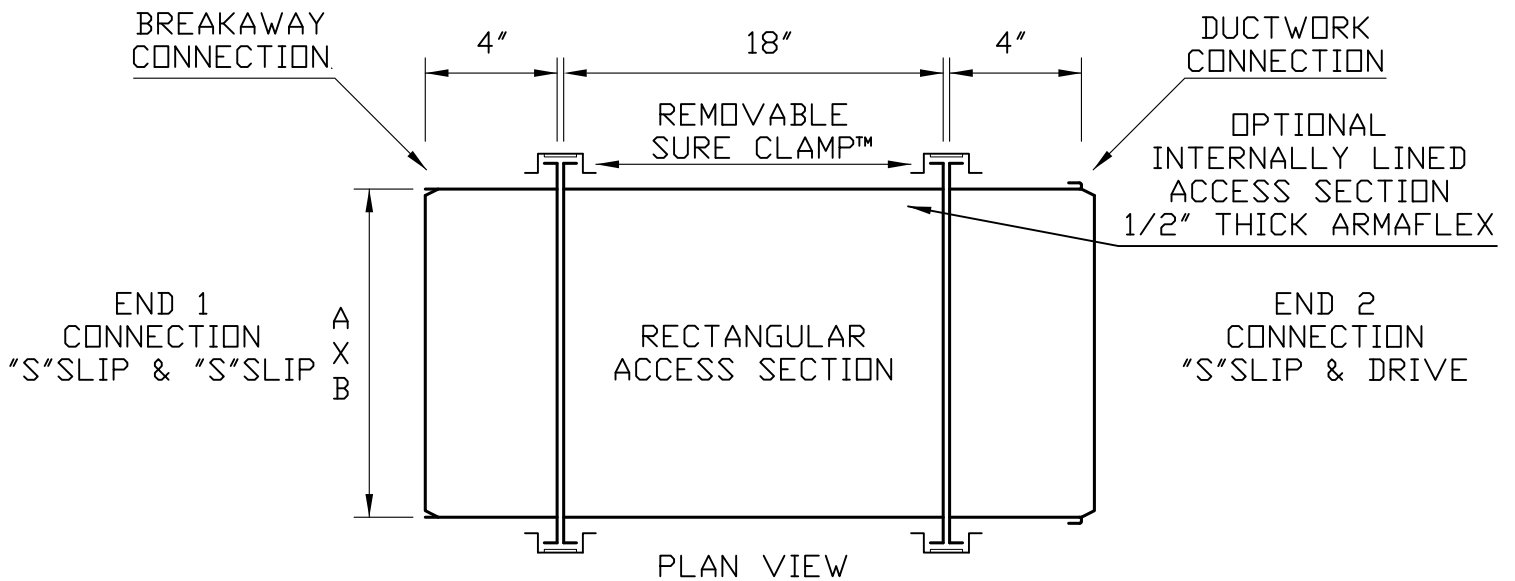

MATERIAL : 26 GAUGE GALVANIZED
 FABRICATE IN ACCORDANCE WITH
 LANGDON'S DUCT CONSTRUCTION STANDARDS
 MAXIMUM ACCESS SIZE 18" X 18"

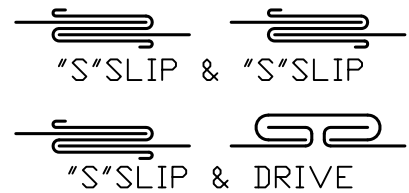

TAG	QTY.	END 1 (A) (B)	LINER
EXAMPLE	1	12" X 8"	YES <input checked="" type="radio"/> NO
_____	_____	X	YES/NO
_____	_____	X	YES/NO
_____	_____	X	YES/NO
_____	_____	X	YES/NO
_____	_____	X	YES/NO
_____	_____	X	YES/NO
_____	_____	X	YES/NO
_____	_____	X	YES/NO

www.langdonsheetmetal.com

ORDER FORM

SURE • CLAMP™ ACCESS

(PATENT PENDING)

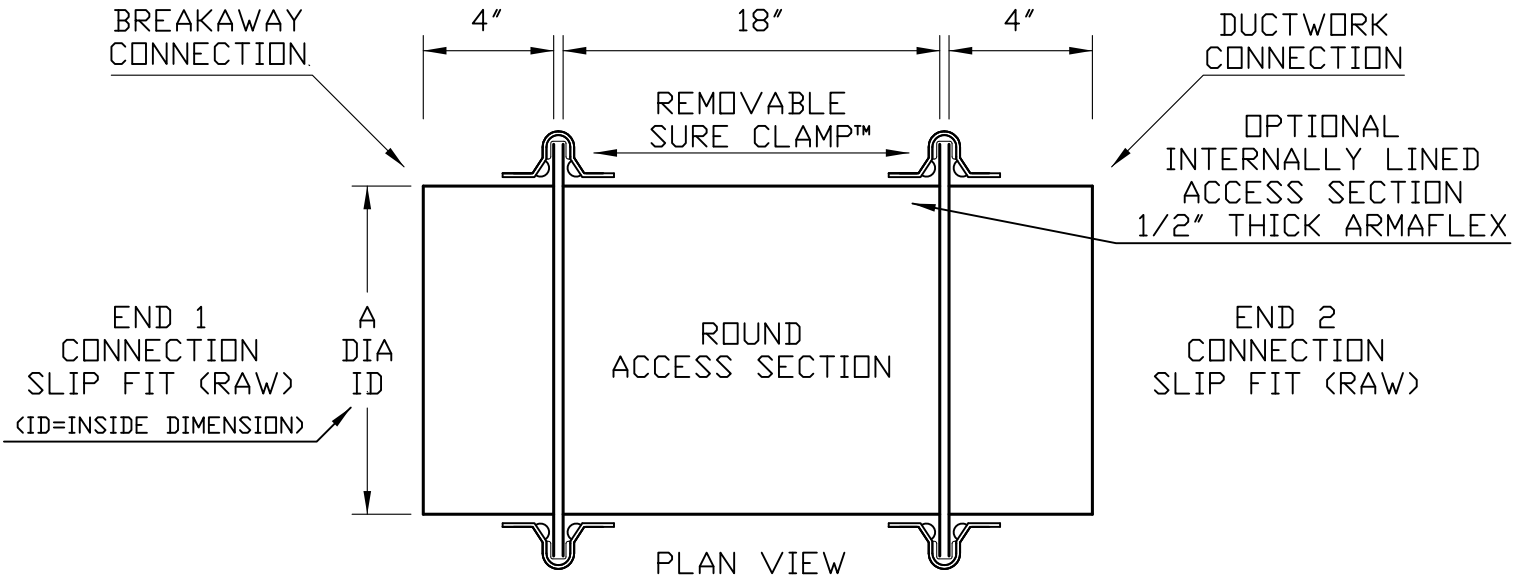

MATERIAL : 4"Ø/12"Ø 22 GAUGE GALVANIZED
 13"Ø/18"Ø 20 GAUGE GALVANIZED

FABRICATE IN ACCORDANCE WITH
 LANGDON'S DUCT CONSTRUCTION STANDARDS

MAXIMUM ACCESS SIZE 18" DIAMETER

TAG	QTY.	END 1 (A) 12"Ø ID	LINER.
EXAMPLE	1		YES <input checked="" type="radio"/> NO
_____	_____	_____	YES/NO
_____	_____	_____	YES/NO
_____	_____	_____	YES/NO
_____	_____	_____	YES/NO
_____	_____	_____	YES/NO
_____	_____	_____	YES/NO
_____	_____	_____	YES/NO
_____	_____	_____	YES/NO
_____	_____	_____	YES/NO

www.langdonsheetmetal.com